

HRB SHLW ROAD BLOCKER

(Anti-terror / Heavy Duty - Shallow Mount Model)



PAS 68 (N3)
IWA 14 (N3C)
ASTM F2656 (C750)



| | |
|------------------------------|---|
| Power | Standard 380V AC 3-Phase 50/60 Hz, 2,2 - 11 kW motor (varies depending on blocker size). Operating with 24V DC in case of power failure is optionally available. |
| Control Pack | 24V DC powered PLC control unit is placed in power unit cabinet. 24V DC (opt.12V DC / 220V AC) solenoids. |
| Speed | Standard operation ~3 - 5 sec. (ascend/descend) depending on road blocker dimensions. Fast raise up (EFO, by optional hydraulic accumulator) ~1 - 1,5 sec. and may differ depending on road blocker dimensions for road blockers wider than 4,0 m. |
| IP Rating | IP55 - Hydraulic Power Unit (optionally electronics control unit with IP67 protection box) IP68 - Hydraulic Piston |
| Operating Temperature | -5°C / +55°C (opt. -30°C / +70°C) |
| Crash / Impact Rating | Crash tested and certified according to: IWA 14-1:2013 Road Blocker V/7200[N3C]/80, PAS68:2013 Road Blocker V/7500[N3]/80, and ASTM F2656-18 C750/7200 standards (HRB 30 P 90 SHLW model). |

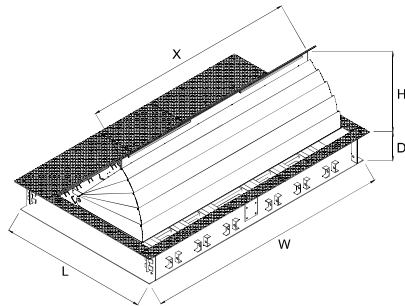

| Product Code | Blocker Unit Width - mm (X) | Nr. of Pistons | Mounting Depth | Raising Height (H) |
|-----------------|-----------------------------|----------------|-------------------------|--------------------|
| | | | 400 mm | 900 mm |
| | | | Dimensions - mm (LxWxD) | |
| HRB 20P 90 SHLW | 2000 | 1 | | 2200 x 2450 x 400 |
| HRB 25P 90 SHLW | 2500 | 1 | | 2200 x 2950 x 400 |
| HRB 30P 90 SHLW | 3000 | 1 | | 2200 x 3450 x 400 |
| HRB 35P 90 SHLW | 3500 | 2 | | 2200 x 3950 x 400 |
| HRB 40P 90 SHLW | 4000 | 2 | | 2200 x 4450 x 400 |
| HRB 45P 90 SHLW | 4500 | 2 | | 2200 x 4950 x 400 |
| HRB 50P 90 SHLW | 5000 | 2 | | 2200 x 5450 x 400 |
| HRB 55P 90 SHLW | 5500 | 2 | | 2200 x 5950 x 400 |
| HRB 60P 90 SHLW | 6000 | 2 | | 2200 x 6450 x 400 |

* Different raising heights are optionally available.

| | |
|---|---|
| Axle Load Resistance | 50 t |
| Hydraulic Cylinder Unit | Dust sealed hydraulic cylinder, developed for heavy duty use. 1 - 3 m wide models contain single piston. 3,5 - 6,0 m wide models contain double pistons. Contains safety valve for hose bursts. |
| Hydraulic Power Unit and Cabinet | Strengthened industrial hydraulic pump. 40 - 120 lt capacity oil tank with magnetic metal collector and suction filter. Built-in oil level indicator and sensor, oil temperature indicator and audio alarm feature for low oil level. Standard 70 - 150 bar pressure (max. 180 bar). 10 m R2 type (double wire braided mesh) reinforced hydraulic hose. |

